

evochlor®

SALT WATER CHLORINATORS

EVOCHLOR

SALT WATER CHLORINATOR

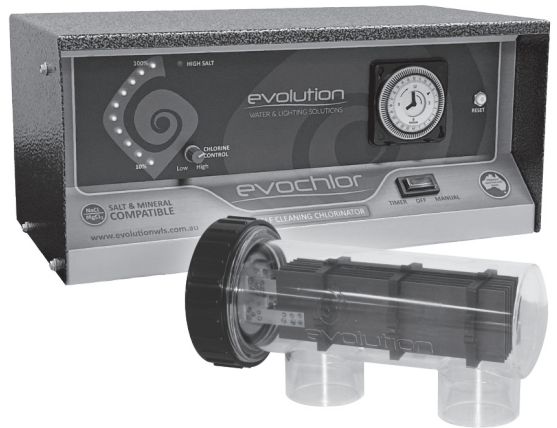

Installation and Operation Manual for **EVOCHLOR AUTOMATIC SELF-CLEANING CHLORINATOR**

A15TS | A20TS | A25TS | A30TS | A35TS

⚠ WARNING

This equipment must be installed and serviced by a qualified technician. Improper installation can create electrical hazards which could result in property damage, serious injury or death. Improper installation will void the warranty.

🔧 NOTICE TO INSTALLER

This manual contains important information about the installation, operation and safe use of this product. Once the product has been installed this manual must be given to the owner/operator of this equipment.

evochlor[®]

SALT WATER CHLORINATORS

TABLE OF CONTENTS

1.0 FOREWORD	1
2.0 POOL CHEMISTRY.	1
3.0 CELL INSTALLATION	2
4.0 POWER PACK INSTALLATION	3
5.0 OPERATION	4
6.0 MAINTENANCE.	6
7.0 TROUBLESHOOTING.	7
8.0 WARRANTY	8
9.0 NOTES	9

1.0 FOREWORD

- 1.1 Congratulations on purchasing an Evolution Evochlor Saltwater Chlorinator for your swimming pool. This system is designed for robust reliability and easy operation to provide many years of trouble-free service. Please read the instructions thoroughly before operating the unit. If you have any concerns or require further assistance, please do not hesitate to contact our friendly staff or any of our Evolution distributors.

2.0 POOL CHEMISTRY

- 2.1 It is important to note that the Evochlor Chlorinator does not maintain the water chemistry of the swimming pool water; it simply produces chlorine from a mild salt solution. To ensure that the water is chemically balanced within the guidelines listed below, the pool water should be tested regularly at a pool shop to maintain a sparkling and healthy pool.

pH	7.2 – 7.6
Total Alkalinity	90 – 150ppm
Cyanuric Acid	40 – 65ppm
Salt	4,000ppm
Chlorine	1.5 – 2.0ppm

- 2.2 The Evochlor Chlorinator is designed to operate on a salt level of 4,000 parts per million (ppm). This is easily achieved by using the formula below, or approximately 20kg of salt for every 5,000 litres.

For example:

$$\begin{aligned}\text{Pool volume} &= \text{Length} \times \text{Width} \times \text{Average Depth} \times 1000 \\ &= 9\text{m} \times 4\text{m} \times 1.5\text{m} \times 1000 \\ &= 54000 \text{ litres}\end{aligned}$$

$$\begin{aligned}\text{Salt required} &= \frac{\text{Pool Volume} \times 4 \text{ (salt level required, 4000ppm)}}{1000} \\ &= \frac{54000 \times 4}{1000} \\ &= 216\text{kg} \\ &\text{Or } 11 \times 20\text{kg bags of pool salt}\end{aligned}$$

- 2.3 **NB: Before adding salt to the swimming pool, please ensure the Evochlor Chlorinator is switched off to avoid overload damage. FAILURE TO DO SO MAY VOID WARRANTY.**
- 2.4 It is recommended to manually add chlorine to the swimming pool on initial startup as a saltwater chlorinator is designed to maintain chlorine levels and not run for unnecessary long hours to try to build an acceptable chlorine level. The manual addition of chlorine may also be required for unforeseen situations where the swimming pool has a high chlorine demand, for example, after a large bather load.

3.0 CELL INSTALLATION

- 3.1 The electrolytic cell housing must be plumbed into the return line after the filter. Please refer to the installation diagram, Fig.1, below for the preferred method. The cell housing has allocations for either 40mm PVC pipe or 50mm PVC pipe with the use of the supplied PVC reducing bushes.
- 3.2 If a heater is plumbed into the system, then the cell housing must be installed after the heater in the return line to protect the elements or heat exchanger. If a solar heating system is fitted, then the cell housing should be installed after the return line coming back from the roof if it rejoins the main swimming pool return line.

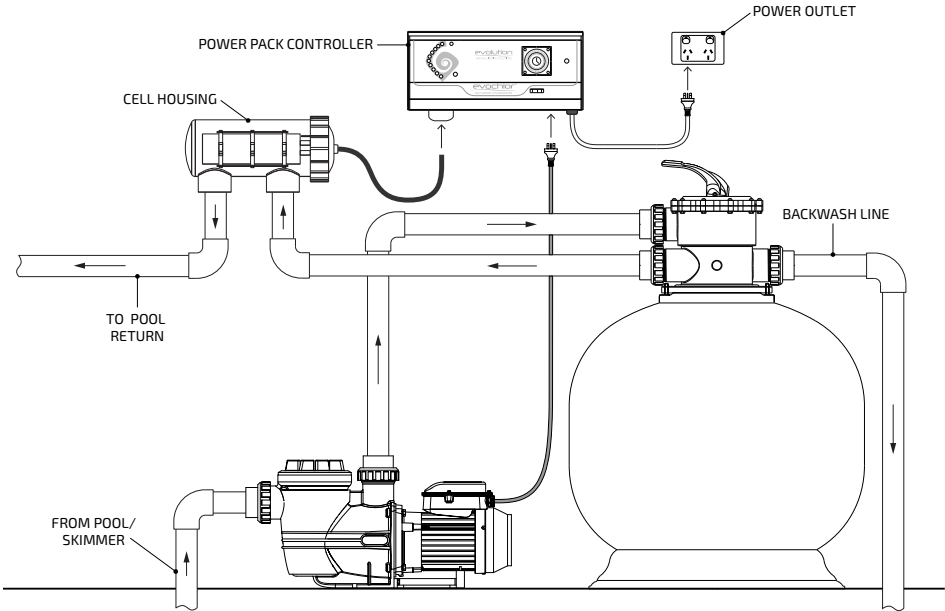

Fig. 1

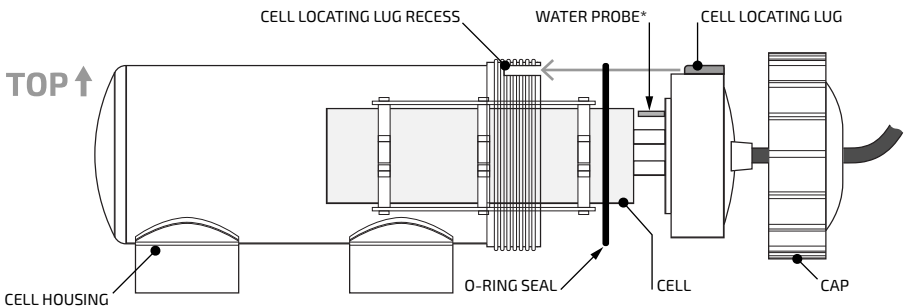

Fig. 2

Please note the installation position of the electrolytic cell for water probe positioning. Water probe faces top.

4.0 POWER PACK INSTALLATION

- 4.1 The Evochlor Chlorinator power pack is wall mounted by either using the supplied mounting bracket or directly hanging on the wall with screws (300mm centres). The power pack is to be mounted at least 1 metre above the ground and 3 metres or more from the pool edge.
- 4.2 It is strongly recommended that the power pack be installed where it is protected from the elements. Rain and sunlight will prematurely age the unit. It should also be mounted in a position where it is away from accidental water spray. The power pack should be installed so that adequate airflow can circulate freely around the unit to allow for sufficient ventilation.
- 4.3 The power pack comes with a standard 230V 10A power cable that is to be connected to mains power. Plug the power cable into a suitable weatherproof outlet.
- 4.4 The power pack is fitted with a 230V 10A power socket located on the right-hand underside of the power pack. The pool pump should be plugged into this socket so that the chlorinator and pump activate together when the timer switches on at the allocated time settings. In a model without a timer, the pump and chlorinator are controlled by the on/off switch (7 in Fig. 3). Failure to plug the pool pump into this socket could lead to the chlorinator staying on with no water circulation. Without circulation, and in the event of a water probe failure, overheating and a possible gas build-up may occur. This build-up may damage the cell housing.
- 4.5 The electrolytic cell cable is connected to the power pack at the junction box on the underside of the unit. With power off, remove the protective cover from the junction box and insert the cell cable wires to the terminals, with the thin wire connecting to the middle position. The screws must be firmly tightened, so there is solid contact between the wires and the terminals. Replace the protective cover back over the junction box.

5.0 OPERATION

5.1 The control interface on the power pack consists of the following.



Fig. 3

1. Chlorine Output LEDs

The output lights follow the curve of the Evolution logo. If the correct salinity level is maintained in the water, then all ten lights will illuminate at full output (100%). Each light represents 10% chlorine output. If all lights are not illuminated, then a higher salinity level will be required. Make sure all salt is dissolved correctly before adding more. The chlorine control (2 in Fig. 3) will increase or decrease the chlorine output to suit the chlorine requirements. If all of the indicator lights flash, then there is a water flow fault.

2. Chlorine Control

The chlorine controller determines the amount of chlorine production. By simply turning the control clockwise, chlorine output is increased, and by turning the control anti-clockwise, chlorine output is decreased. Do not force the control past its stop as this will damage the unit and void warranty.

3. High Salt Light

This light is a red warning indicator and will illuminate when the salt level in the swimming pool is higher than 4500ppm. If this light is on, together with the ten output LED's (1 in Fig. 3), decrease the output by turning the chlorine control (2 in Fig. 3) anticlockwise until the high salt (red light) goes off, and all ten chlorine output LEDs remain on. If this light is the only one illuminated then the unit has gone into the over-temperature cutout and will reset once back to normal running temperature.

4. Polarity Light

The polarity light is the first indicator light, 10% in the chlorine output array (1 in Fig.3). This light will alternate between orange and green every reversing cycle, 4-12 hours. The factory setting is a 12-hour cycle.

5. Timer

The FM/1 series time switch is a 24-hour timer for controlling the chlorinator and associated circulation pump.

Setting the Timer

To set the time, turn the minute hand clockwise until the time of day on the outer dial is aligned with the arrow on the inner dial. For example, to set the chlorinator and pool pump for 8.00pm, adjust the timer as per Fig. 4. The inner dial on the timer has 24 hr markings with 15-minute increments. Turn the minute hand clockwise until 20, or 8.00pm, is aligned with the arrow on the inner dial. The hour and the minute dial will correspond to 8.00pm. It is important to make sure that if the time is set to 8.00pm then the mark on the inner dial must point to 20, not 8, which would be 8.00am.

The time switch is programmed by pushing the captive trippers to the outer ring position for the entire period that the chlorinator and pump are to be turned "ON", i.e. each segment corresponds to 15 minutes on the 24-hour dial. When the tripper is pushed inwards, the timer is in the "OFF" position.

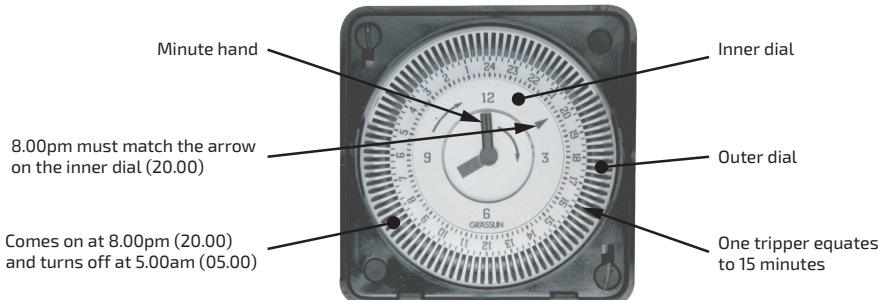

Fig. 4

6. Circuit Breaker

The circuit breaker mounted on the front right-hand side of the Evochlor chlorinator is designed to trip out in the event of a power surge or overload. When tripped, the yellow centre button will pop out, shutting down the unit. To reset, press the yellow centre button back in to resume normal function.

NB: Turn off the chlorinator at the power point before attempting to reset the circuit breaker. Should the circuit breaker continue to trip, then a local Evolution distributor should be contacted.

7. Switch

This switch allows you to choose the timer operation mode for the chlorinator and pool pump. Switched to the left position, Timer, enables the chlorinator and pool pump to turn off and on at the designated timer settings. The Manual selection, to the right, allows the chlorinator and pump to work continuously until the switch setting is physically changed. The Off position in the middle will turn power off to the chlorinator and circulation pump.

6.0 MAINTENANCE

- 6.1 It is recommended that a pool water sample is taken to a pool shop and tested once per month for analysis. Please refer to Pool Chemistry (section 2.0) for additional information.
- 6.2 The electrolytic cell operates most efficiently when it is clean. As a natural result of the electrolytic process, which creates chlorine from salt molecules, calcium is attracted to the titanium plates in the cell. The self-cleaning feature helps to inhibit such build-up and scaling. However, the attraction of calcium and other minerals is inevitable, and eventually, it must be removed.
- 6.3 The transparent housing of the cell allows easy visual inspections, and with correct water chemistry, the cell will only need cleaning approximately every 3-6 months. In regions with hard water (high calcium levels), more frequent cleaning may be required.
- 6.4 To clean the cell follow these instructions:
1. Turn off power to the chlorinator and pump.
 2. Remove the cell from the cell housing by loosening the cell collar and pull the cell out of the housing. If required, disconnect the cell cable wires at the junction box underneath the power pack (these must be re-connected firmly and tightly).
 3. With the cell removed use a high-pressure hose nozzle to spray off as much loose scale as possible. Do not use any sharp or metallic objects to remove scale as this will damage the cell.
 4. If further cleaning is required, the cell needs to be cleaned in a mixture of 1 part Hydrochloric Acid to 10 parts water. Mix the acid solution in a bucket or tub that will fit the cell.
 5. **!WARNING:** Chemical Hazard - When mixing acid with water, always add the acid to the water, never add water to the acid. When using the acid, ensure to use rubber gloves and appropriate eye protection and follow safety directions on the Hydrochloric Acid label.
 6. Place the cell into the cleaning solution submerging the plates and ensuring that the cell head does not come in contact with the acid solution. Once the cell is clean, remove it from the cleaning solution and rinse. Replace the cell into housing in a reverse manner to the steps above.
- 6.5 Only qualified electrical technicians should service the power pack. For the nearest Evolution recommended service technician, please contact Evolution Water & Lighting Solutions on +61 7 5565 0000 or email us at repairs@evolutionwls.com.au.

7.0 TROUBLESHOOTING

Fault/Problem	Possible Cause	Remedy
NO FLOW All chlorine output LED's flashing	Pump turned off.	Ensure the pump is on.
	Closed valve.	Open valve.
	Air in the system.	Check all o-rings and grease.
	Dirty filter.	Clean or Backwash filter.
	Low water level.	Fill up the pool.
HIGH SALT Red LED illuminated	Calcium build-up on Water Probe sensor.	Clean probe in a mild hydrochloric acid solution, see page 6.
NO LIGHTS	Salt level too high, above 4500ppm.	Turn chlorine control anticlockwise until salt levels reduce.
	Circuit Breaker tripped.	Reset Circuit Breaker. If it trips again immediately call a technician.
LOW / NO CHLORINE PRODUCTION	Mains power failure.	Check switches and switchboard circuit breaker.
	Chlorine output too low.	Increase chlorine production, turn chlorine control clockwise.
	Salt level too low.	Increase salt level to 4000ppm and check stabiliser (Cyanuric) levels.
	pH too high.	Adjust pH between 7.2 - 7.6
	Timer period too short.	Increase running time.
ABNORMAL CALCIUM BUILD-UP ON CELL	High phosphate levels.	Treat pool water with phosphate remover.
	Cell connections not secure.	Check connections at junction box under the unit.
TIMER TIMES OUT OF SYNC	Calcium level in pool water is extremely high or unbalanced water chemistry.	Have water tested and balanced as per Langlier Saturation Index. Clean cell with mild HCl solution.
	Timer is not set correctly.	Check setting procedure as per page 5.
	Chlorinator installed on off-peak tariff.	The timer will need battery backup if installed on off-peak tariff.
OVER TEMPERATURE Red LED Illuminated Only (no other lights)	Timer / Off / Manual switch not selected correctly.	Make sure switch is selected correctly, see page 5.
	Salt Level too high, above 4500ppm.	Turn chlorine control anticlockwise until salt levels reduce.
	Unit is installed in an area where the ambient temperature is extremely high.	Supply adequate cooling. Install outside of the extreme temperature area.

8.0 WARRANTY

- 8.1 Evolution Evochlor Chlorinators are covered by a 3-year full warranty from the date of purchase. The power pack and electrolytic cell are covered against defects in materials and assembly from the date of purchase in a domestic application. All electrical or mechanical failure due to faulty components will be repaired or replaced at no cost to the owner, including labour. Warranty will not be covered without proof of purchase, so keep the original purchase invoice in a safe place.
- 8.2 In field labour is limited to the Gold Coast city metropolitan area. Outside of these areas the complete unit should be returned to Evolution Water & Lighting Solutions or one of our warranty agents. Freight charges may apply and are entirely at the discretion of Evolution Water & Lighting Solutions. Please contact us in regards to an authorised warranty agent in your area.
- 8.3 The warranty will be void due to unfavourable environments and operating conditions beyond the control of the manufacturer. These include but are not limited to: incorrect power supply (Must be 230V, 50Hz), the chlorinator connected to an ancillary device such as a Variable Frequency Drive, wear and tear, water and insect damage, extreme ambient temperatures or any other adverse situation that affects the unit. All warranties only apply if the equipment is installed and operated in complete compliance with the installation and operating instructions.
- 8.4 Evochlor Chlorinators and electrolytic cells installed in a commercial situation are covered by a 1-year warranty. Commercial situations include motels/hotels, health spas, apartment/townhouse complexes and any location with an unusually high bather load or abnormal conditions.
- 8.5 Evolution Water and Lighting Solutions will not accept liability for any consequential loss or damage of any kind.

For all warranty enquiries, please do not hesitate to call +61 7 5565 0000 or email service@evolutionwls.com.au

IMPORTANT

Please attach sales invoice/receipt here as a proof of purchase should warranty service be required. Please keep warranty form and retain for records.

Purchased from:
Purchase date:
Serial No:
Model No:

evolution

WATER & LIGHTING SOLUTIONS

Evolution Water and Lighting Solutions

1/33 Hinkler Drive, Highland Park QLD 4211, Australia +61 7 5565 0000

Unless otherwise indicated, copyright in the content of this document is the property of Evolution Water and Lighting Solutions under Australian copyright law. Unless otherwise indicated, content may not be reproduced or transmitted without our prior written permission.

© 2020 Evolution Water and Lighting Solutions. All rights reserved.